

CONVEY WEIGH

• Belt Scale Data Sheet •

Company _____ **Contact** _____
Address _____ **Phone** _____
City, State, Country _____ **Fax** _____
Zip Code _____ **E-mail** _____

Belt Scale Accuracy (%) _____ **Scale Type (Idlers)** _____
Material _____ **Material Size** _____

Conveyor Belt Width _____ **Length** _____ **Belt Speed** _____
Normal Belt Capacity _____ (TPH), **Maximum Belt Capacity** _____ (TPH)

Idler Spacing _____ **Idler Foot Pad** _____ ("A") (Center to Center)
Idler Angle ("B"): Flat o; 20 deg. o; 35 deg. o; 45 deg. o
Idler Roller Diameter: 4in. o; 5in. o; 6in. o **Roller Height ("D")** _____

Conveyor Structure Width: _____ ("C" Outside) **Incline Angle** _____ ° **Toe:** In o; Out o
Take Up Type: Gravity o; Screw o; Hydraulic o; None o
Access Side: Left o; Right o **Access Width** _____ **Conveyor Covered Y:** No

Note Any Unique Situations: _____

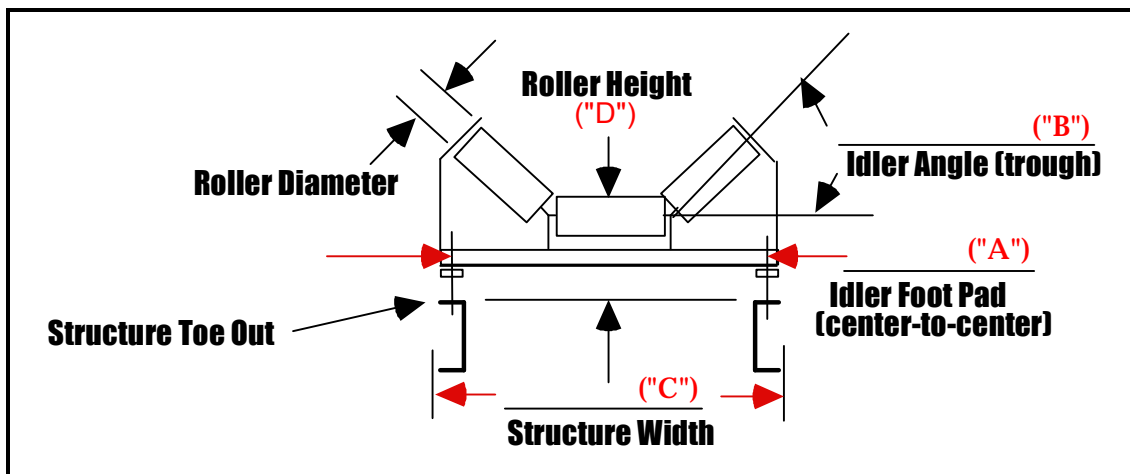

Return Fax: 1-304-755-3883